

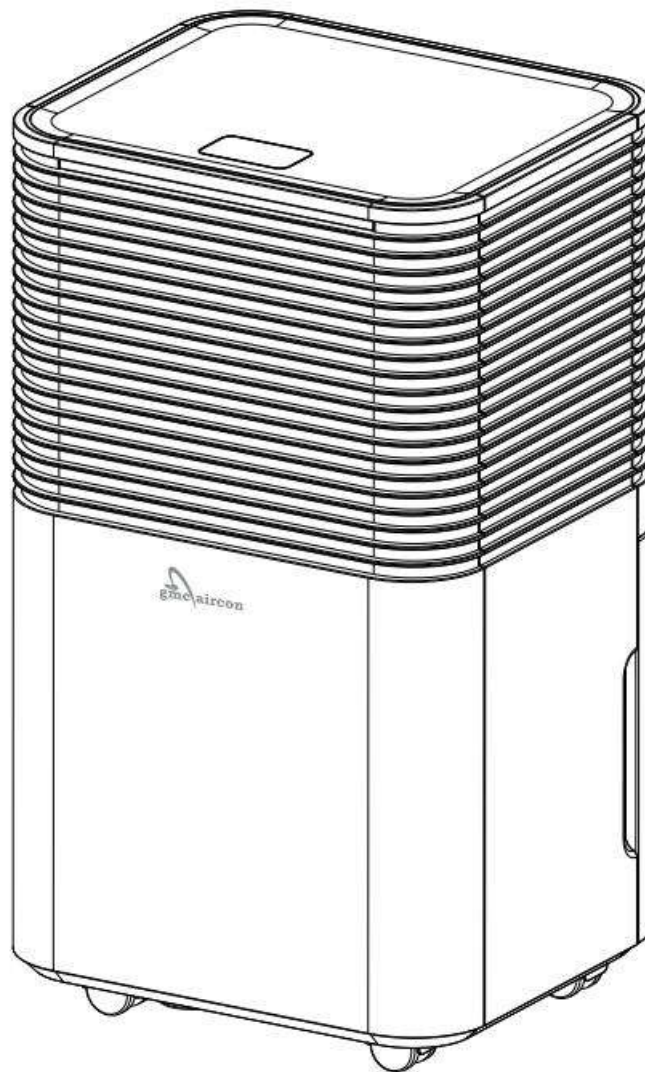

Dehumidifier

Instruction Manual



CONTENTS

COVER PAGE	1
CONTENTS	2
IMPORTANT NOTES	3
SAFETY INFORMATION	4,5,6,7,8
PARTS	8
INSTALLATION	9
OPERATIONS	10,11,12,13
WATER DRAINAGE	14,15
MAINTENANCE	16,17
SPECIFICATIONS/FEATURES	18
TROUBLESHOOTING	19
DECOMMISSIONING	20
SERVICE AND WARRANTY	21

IMPORTANT NOTES

Dear Customer

Your new GMC Dehumidifier has been manufactured in a state-of-the-art facility and has passed the strictest quality control procedures. Please read this manual carefully before using your appliance for the first time and then please store this manual in a safe place for future reference.

Thank you again for choosing GMC. If you have any issues at all with your product or any questions then the quickest route for resolution is to please contact us through our website www.gmcaircon.co.za or on +27 12-661-1173. We will be able to resolve any issues that may arise and our technical team is always on hand for assistance. We pride ourselves on 100% customer satisfaction and we trust you will enjoy your new product.

Record in the space below the listed information for future reference.

SERIAL NUMBER.....

DATE OF PURCHASE.....

PURCHASED FROM.....

.....



Do not attempt to maintain the appliance yourself. Only authorised agents are to carry out repairs.

When first using the dehumidifier, operate the unit continuously for 24hrs, the humidity level can be set within a range of 80% RH (Relative Humidity) in 5% reduce or at CO for continuous operations. NOTE: If CO (Continuous) is selected, the dehumidifier will operate continuously at its maximum dehumidification settings if attached to a hose or drain or until the bucket is full.

For drier air, press the - pad and set to a lower percent value (%). For damper air, press the + pad and set to a higher percent value (%). When you first use the dehumidifier, set the humidity control to 45% or 50%, allow at least 24hrs for the dehumidifier to achieve the desired humidity level. If you still have damper air than

desired, set the humidity level to a lower setting or select continuous for maximum dehumidification.

SAFETY INFORMATION



Please read this manual carefully and fully understand before operating your dehumidifier.

1 OPERATIONAL PRECAUTIONS

- If the supply cord is damaged, it must be replaced by the manufacturer, its service agent or similarly qualified persons in order to avoid a hazard.
- The appliance shall be disconnected from its power source during maintenance.
- Always operate the unit from a power source of equal voltage, frequency and rating as indicated on the product identification plate.
- Always use a power outlet that is grounded.
- Unplug the power cord when cleaning or when not in use.
- Do not operate with wet hands. Prevent water from spilling onto the unit.
- Do not immerse or expose the unit to rain, moisture or any other liquid.
- Do not leave the unit running unattended. Do not tilt or turn over the unit.
- Do not unplug while the unit is operating.
- Do not unplug by pulling on the power cord.
- Do not put objects on the unit.
- Do not climb or sit on the unit.
- Do not insert fingers or other objects into the air outlet.
- Do not touch the air inlet or the aluminum fins of the unit.
- Do not operate the unit if it is dropped, damaged or showing signs of product malfunction.
- Do not clean the appliance with any chemicals.
- Ensure the unit is far away from fire, inflammable, or explosive objects.
- The unit shall be installed in accordance with national wiring regulations.

- Do not use means to accelerate the defrosting process or to clean, other than those recommended by the manufacture.
- The appliance shall be stored in a room without continuously operation sources (for example: open flames, an operating gas appliance or an operating electric heater).
- The appliance shall be stored so as to prevent mechanical damage from occurring.
- Pipe-work shall be protected from physical damage and shall not be installed in an unventilated space, if that space is smaller than 4m².
- Compliance with national gas regulations shall be observed.
- Keep any required ventilation openings clear of obstruction.
- The appliance shall be stored in a well-ventilated area where the room size corresponds to the room area as specified for operation.



Any person who is involved with working on or breaking into a refrigerant circuit should hold a current valid certificate from an industry-accredited assessment authority, which authorizes their competence to handle refrigerants safely in accordance with an industry, recognized assessment specification.



Servicing shall only be performed as recommended by the equipment manufacturer. Maintenance and repair requiring the assistance of other skilled personnel shall be carried out under the supervision of the person competent in the use of flammable refrigerants. If you don't understand something or need help, please contact the dealer services

2.SAFETY PRECAUTIONS ON SERVICING

Please follow these warnings when to undertake the following when servicing a dehumidifier.

2.1 Checks to the area

Prior to beginning work on systems containing flammable refrigerants, safety checks are necessary to ensure that the risk of ignition is minimized. For repair to the refrigerating system, the following precautions shall be complied with prior to conducting work on the system.

2.2 Work procedure

Work shall be undertaken under a controlled procedure so as to minimize the risk of a flammable gas or vapor being present while the work is being performed.

2.3 General work area

All maintenance staff and others working in the local area shall be instructed on the nature of work being carried out. Work in confined spaces shall be avoided. The area around the workspace shall be sectioned off. Ensure that the conditions within the area have been made safe by control of flammable material.

2.4 Checking for presence of refrigerant

The area shall be checked with an appropriate refrigerant detector prior to and during work, to ensure the technician is aware of potentially flammable atmospheres. Ensure that the leak detection equipment being used is suitable for use with flammable refrigerants, i.e. no sparking, adequately sealed or intrinsically safe.

2.5 Presence of fire extinguisher

If any hot work is to be conducted on the refrigeration equipment or any associated parts, appropriate fire extinguishing equipment shall be available to hand. Have a dry powder or CO₂ fire extinguisher adjacent to the charging area.

2.6 No ignition sources

No person carrying out work in relation to a refrigeration system which involves exposing any pipe work that contains or has contained flammable refrigerant shall use any sources of ignition in such a manner that it may lead to the risk of fire or explosion. All possible ignition sources, including cigarette smoking, should be kept sufficiently far away from the site of installation, repairing, removing and disposal, during which flammable refrigerant can possibly be released to the surrounding space. Prior to work taking place, the area around the equipment is to be surveyed to make sure that there are no flammable hazards or ignition risks. "No Smoking" signs shall be displayed.

2.7 Ventilated area

Ensure that the area is in the open or that it is adequately ventilated before breaking into the system or conducting any hot work. A degree of ventilation shall continue during the

period that the work is carried out. The ventilation should safely disperse any released refrigerant and preferably expel it externally into the atmosphere.

2.8 Checks to the refrigeration equipment

Where electrical components are being changed, they shall be fit for the purpose and to the correct specification. At all times the manufacturer's maintenance and service guidelines shall be followed. If in doubt consult the manufacturer's technical department for assistance.

The following checks shall be applied to installations using flammable refrigerants:

- The charge size is in accordance with the room size within which the refrigerant containing parts are installed;
- The ventilation machinery and outlets are operating adequately and are not obstructed;
- If an indirect refrigerating circuit is being used, the secondary circuit shall be checked for the presence of refrigerant;
- Marking to the equipment continues to be visible and legible. Markings and signs that are illegible shall be corrected;
- refrigeration pipe or components are installed in a position where they are unlikely to be exposed to any substance which may corrode refrigerant containing components, unless the components are constructed of materials which are inherently resistant to being corroded or are suitably protected against being so corroded.

2.9 Checks to electrical devices

Repair and maintenance to electrical components shall include initial safety checks and component inspection procedures. If a fault exists that could compromise safety, then no electrical supply shall be connected to the circuit until it is satisfactorily dealt with. If the fault cannot be corrected immediately but it is necessary to continue operation, an adequate temporary solution shall be used. This shall be reported to the owner of the equipment so all parties are advised.

Initial safety checks shall include:

- those capacitors are discharged: this shall be done in a safe manner to avoid possibility of sparking;
- that there no live electrical components and wiring are exposed while charging, recovering or purging the system;
- that there is continuity of earth bonding

PRODUCT OVERVIEW/PARTS

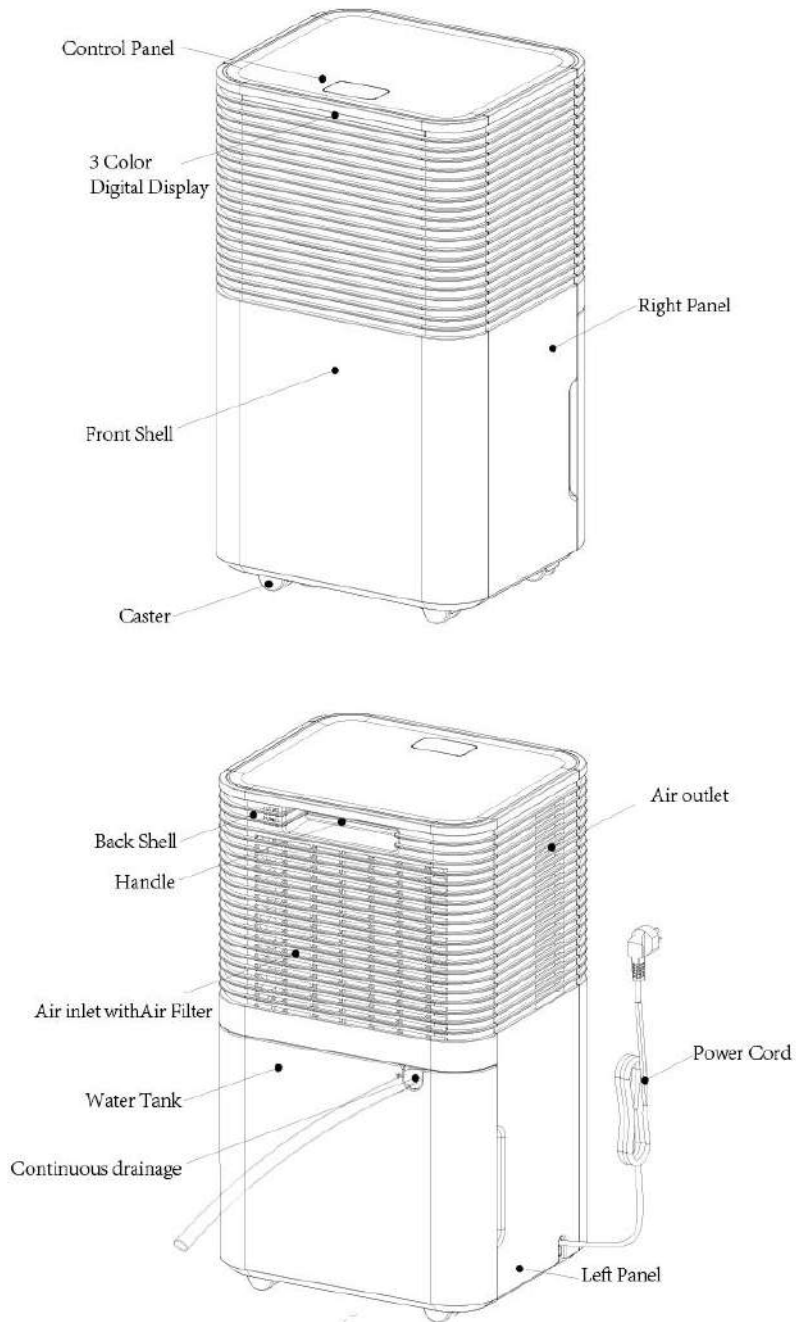

PRODUCT INSTALLATION

4.1 LOCATION

1. Place the unit on a firm, level surface in an area with at least 30cm of free space around it to allow for proper air circulation.
2. Never install the unit where it could be subject to:
 - Heat sources such as radiators, heat registers, stoves or other products that produce heat.
 - In an area where oil or water may be splashed
 - Direct sunlight
 - Mechanical vibration or shock
 - Excessive dust
 - Lack of ventilation, such as cabinet or bookcase
 - Uneven surface

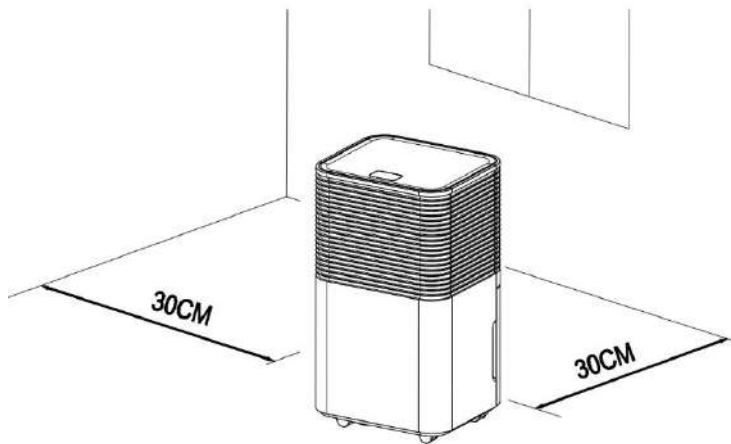

WARNING

Install the unit in rooms which exceed 4 m².

Do not install the unit in a place where inflammable gas may leak.

OPERATIONS

5.1 CONTROL PANEL



POWER

After switching on the power, all the indicators and the screen will be on for 1 second and then off. After a buzzer, the power indicator will be on and the machine will be in standby mode.

Press this button, the machine starts to run, the machine initial humidity is 60%RH, default automatic mode and high wind operation.

Press this key again, the machine will stop running, and the fan will be closed.



HUM

In automatic mode or sleep mode, you can operate this key to adjust the set humidity: every time you press the set humidity increase by 5%, according to the cycle of 30%-80%. Long press this key to query the current room temperature, double eight lights display the current room temperature 5 seconds after the automatic return to display the current humidity. If this key is pressed for a long time, it will be displaying the ambient temperature.



MODE

Auto mode - continuously drying mode-sleeping mode cycle, press once to switch the mode from one to another, the corresponding indicator lights up.

- **Auto mode:** when environmental humidity \geq set humidity +3%, the fan starts working and compressor starts working after 3 seconds.

When environmental humidity \leq set humidity -3%, the compressor stops working and the fan delay shutdown.

Both fan speed and humidity can be adjusted under auto mode.

- **Continuously drying mode:** The machine continues to run, but the humidity cannot be adjusted.

- **Sleeping mode:** Touch the sleep button, the button lights up and start the sleep function. After no operation in 10 seconds, all indicators turn dark gradually and the fan speed is automatically switched from high to low. Touch any button to activate the indicator. Touch sleep button again to exit the sleep mode.

In sleep mode, the fault code is not displayed, the fan speed is not adjustable, and the humidity is adjustable.



TIMER

Press this key to set the timer function of 0-24 hours. The interval is 1 hour. Each time you press this button, the value increased 1 hours and then the corresponding timing value is displayed on the screen. The setting value is "00" to cancel the timer function. The indicator turns off.

After the timer is set and completed, the timer LED is on during the timing period. After the timing is over, the timer LED turns off automatically.

In the running state, set the time to turn off the machine; in the standby state, set the time to turn on the machine.



SPEED

The fan speed can only be adjusted in the automatic mode. Press this key to switch the high and low fan speed. The corresponding wind speed indicator lights up.



LOCK

Long press this key to open the child lock function. The child lock indicator light is on. All the keys are locked and cannot be operated. Press this button again, the indicator light will go out, and the button will be restored.

Open the child lock function, as long as the shutdown or power off will automatically cancel the child lock function.

Colour Digital Display:

Ambient Humidity <45%, The light shows Blue

45≤Ambient Humidity ≤65% , The light shows Green

Ambient Humidity >65% , The light shows Red

If the LED display E0、 E2、 CL、 CH、 LO、 HI, the light will show red.

E2 Humidity sensor problem - Change a sensor

LO Environmental humidity is below 20% - The dehumidifier shuts down for self-protection

HI Environmental humidity is above 90% - The dehumidifier shuts down for self-protection

CL Low temperature protection, the environmental temperature<5°C - The dehumidifier shuts down for self- protection

CH High temperature protection, the environmental temperature>38°C - The dehumidifier shuts down for self- protection

DRAINAGE

EMPTYING THE WATER TANK

- When the tank is full, the unit will make a buzzing sound, and the "Water Full" light will turn on.
- Press the POWER button to turn off the unit.
- Pull on the water tank and simply slide it out of the body of the dehumidifier.
- Empty the water into an area with a drain or an outside drainage area.
- Clean the inside of the tank as well as the outside.
- Replace the empty tank back into the unit.
- Press the POWER button to resume operating.
- If the Water Full light does not extinguish, check that the float is correctly in place.

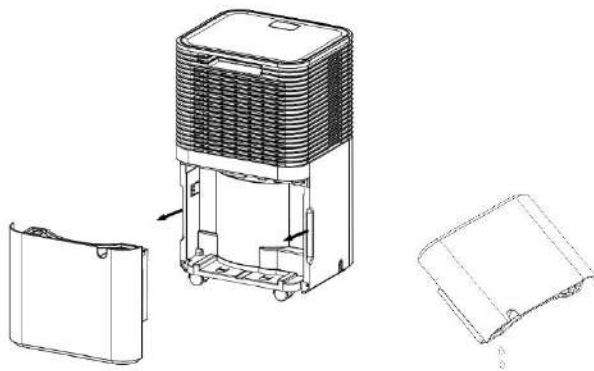

Warning

1. Do not discard water tank magnets and plastic rivets. Otherwise, the machine will not automatically stop working when the water tank is full, and the condensed water will overflow and damage the floor of the room.

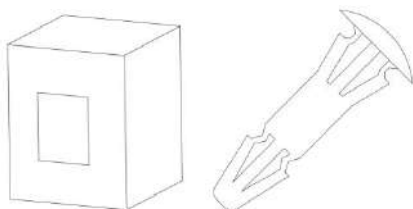

2. Please be sure to clean the condensed water in the water tank before resetting the working mode of the machine.

3. If the water tank is dirty, rinse it with clean water. Avoid using detergents, steel balls, chemical dust removers, diesel oil, benzene, diluents or other solvents. Otherwise, the water tank will be damaged and leak
4. Replace the empty tank back into the unit. Otherwise, the water full indicator may remain red and the machine cannot restart.

CONTINUOUS DRAINING

For continuous operation or unattended dehumidification, please connect the attached drain hose to the unit. Condensate water can then automatically flow into a bucket.

1. Straighten the drainage pipe to prevent kinks or severe bends

2. Insert one end of the drain into the drain into the cistern hole and connect the other end to the bathroom, outdoor or bucket like container, or the prescribed drainage area.

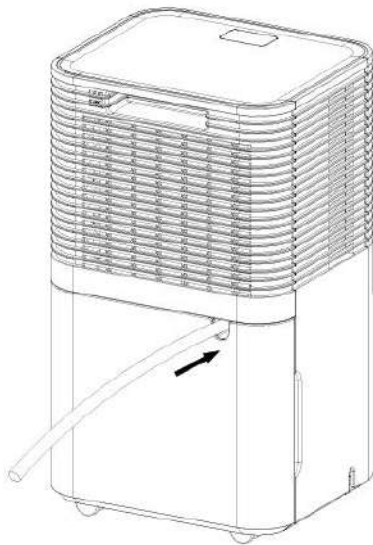

Warning

1. Please do not block the drain or drain pipe, if the drain pipe is blocked the water will flow back into the water tank.
2. Please do not bend the drain pipe. The height of the drain pipe should be lower than the outlet so gravity can allow the correct flow of water.
3. The drain pipe shall be securely connected to the outlet.

MAINTENANCE

Note: before cleaning and maintaining the machine, be sure to turn off the machine and pull the power plug to prevent electric shock.

- **CLEANING THE AIR FILTER** (every two weeks)

Dust collects on the filter and restricts the airflow. The restricted airflow reduces the efficiency of the system and if it becomes blocked it can cause damage to the unit.

The air filter requires regular cleaning. The air filter is removable for easy cleaning. Do not operate the unit without an air filter, or the evaporator may be contaminated.

1. Take the water tank from the body, and then pull out the filter from the bottom of the rear shell;

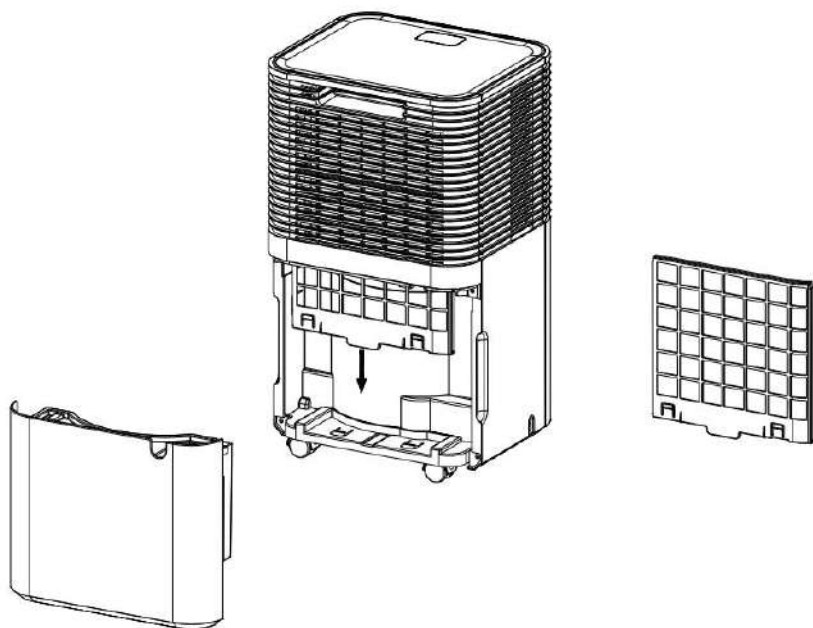

2. Use a vacuum cleaner to gently absorb the dust on the surface.

If the filter is very dirty, wash it with water and a soft detergent and dry it thoroughly afterwards.

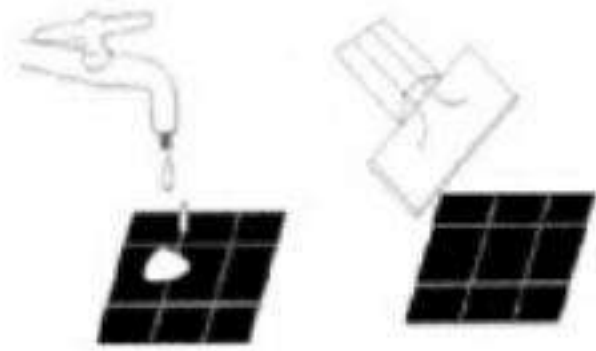

3.Put the filter back.

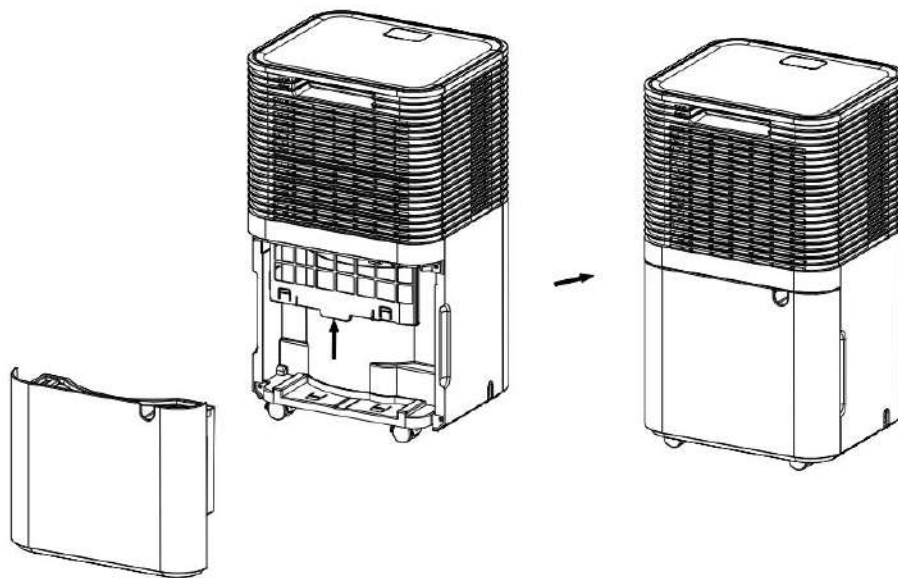

SPECIFICATIONS AND FEATURES

SPECIFICATIONS:

Dehumidifying Capacity (Litre/Day)	: 12Liter/Day
Room Size	: 8-15m ²
Water Tank Capacity (Litre)	: 2.0Liter
Power Supply	: 220-240V/50Hz
Rated Input W (Cooling) 12L	: 200W
Rated Current Amps (Cooling)	: 1.1A
Refrigerant/Charge	: R134A
Air Circulation	: 120m ³ /h
Decibel Rating	: ≤38dB(A)
Body Size (mm)	: W255*D220*H445mm
Carton Size (mm)	: W305*D265*H500mm
Net Weight	: 10kg
Gross Weight	: 11 kg
Application Area	: 15m ²
Control Type	: Touch panel

FEATURES:

1. 12Liter Per Day
2. Eco-Friendly R134A Refrigerant
3. Low Noise ≤38dB(A)
4. LED display and Electronic Control
5. High Efficiency Dehumidifying capacity with a high-quality compressor.
6. 24-hour timer
7. Water-full indicator (with direct drainage option)
8. Touch panel
9. 3 colour indicators to show different ambient humidity
10. Auto – restart after power interruption

TROUBLE SHOOTING

FUNCTIONING TEMP.

5°C ≤ Ambient Temp. ≤ 35°C

When the ambient temp is lower or higher than the functioning temp, the dehumidifier stops. When 5°C ≤ Ambient temp. ≤ 16°C, the compressor automatically defrosts at intervals; during defrosting, the compressor stops and the fan keeps running.

BEFORE CALLING FOR SERVICE

Before contacting professional service, please review the trouble shooting list that includes common occurrences that are not the result of a defect in workmanship or materials.

Problem	Possible Cause	Solution
Not working	No power supply	Connect to a functioning outlet and switch on
	Water Full Indication Flashes	Drain water tank and reset it, or re-position the water tank to right place
	Room temperature < 5°C, or > 35 °C	Self-Protection designed to protect the unit. Cannot work under such temperature
Bad functioning	Is the air filter clogged?	Clean the air filter as instructed
	Is the intake duct or discharge duct obstructed?	Remove the obstruction from the discharge duct or intake duct.
No air intake	Is the filter clogged?	Wash the filter
Loud noise when running	Is the machine on a level surface?	Put the machine on a level surface.
	Is the filter clogged?	Wash the filter
E2	Humidity sensor problem	Change a sensor. Please contact our customer support
LO	Environmental humidity is below 20%	The dehumidifier shuts down for self-protection. It start up automatically once conditions normalize
HI	Environmental humidity is above 90%	
CL	Low temperature protection, the environmental temperature < 5°C	
CH	High temperature protection, the environmental temperature > 38°C	

DECOMMISSIONING

STORAGE

Long-term storage - If you will not be using the unit for an extended period of time (more than a few weeks) it is best to clean the unit and dry it out completely. Please store the unit per the following steps:

1. Press power button to switch off and unplug the unit.
2. Drain the remaining water from the unit.
3. Clean the filter and let the filter dry completely in a shaded area.
4. Collect the power cord at the water tank.
5. Re-install the filter at its position.
6. The unit must be kept in upright position when in storage.
7. Preserving the machine in ventilating, dry, non- corrosive gas and safe place indoor.

ATTENTION:

The evaporator inside the machine has to be dried out before the unit is packed to avoid component damage and molds. Unplug the unit and place it in a dry open area for days to dry it out. Another way to dry the unit is to set the humidity point more than 5% higher than the ambient humidity to force the fan to dry the evaporator for a couple of hours.

DISPOSAL

WARNING!!!

Releasing refrigerant into atmosphere is strictly forbidden!

Do not dispose of electrical appliances as unsorted municipal waste, use separate collection facilities. Contact your local government for information regarding the collection systems available. If electrical appliances are disposed of in landfills or dumps, hazardous substances can leak into the groundwater and get into the food chain, damaging your health and well-being



SERVICE AND WARRANTY

GMC Airconditioning CC was established in 1995 and is one of South Africa's leading cooling and heating companies. We pride ourselves on 100% customer satisfaction and have the highest online rating of all heating and cooling companies in South Africa. We will strive to ensure you are 100% satisfied with your product.

In the rare case of encountering any issues with your product or would like some support please contact us directly on +27 12-661-1173 or www.gmcaircon.co.za as this will allow us to react quickly to your request. If you have bought this product from one of our partner platforms, then contacting us directly will allow us to resolve the issue for you in a timelier fashion. We are here to help you and ensure you are 100% satisfied.

Please read this instruction manual carefully before setting up or using this product. If you believe this product to be suffering from a manufacturing fault, or if you have any inquiries about this product, please contact our customer support.

CUSTOMER SUPPORT

GMC Airconditioning CC

35 Sarel Baard Crescent

Gateway Industrial Park

Centurion

0046

Telephone: +27 (12) 661-1173

Website: www.gmcaircon.co.za

Email: info@gmcaircon.com

When contacting our customer support, please have the information below available. All warranty requests must be accompanied by a proof of purchase, which is a copy of the original receipt.

Model:

Date of purchase:

Purchased from:

